

ANALYSIS OF SOLAR POWER SUPPLY UNIT IN THE OPTIMIZED DESIGN FOR APPLICATIONS OF INTERNET OF THINGS AND GREEN CAMPAIGNS.

CHAKSHU GUPTA

ABSTRACT

To plan a solar oriented based force supply unit that can supplant ordinary force supply in the Internet of Things (IoT) gadgets explicitly PCs without trading off the productivity of the gadgets. It likewise assists with limiting the proportion of Co2 discharge of advanced gadgets which is a major risk nowadays for the condition. Essentially, a circuit of DC power supply unit is plan for personal computers. These PCs can take a shot at 12 volts DC power supply in green registering conditions. Additionally, 5 and 3 volts are produced for the starting force and interior parts of the PC. In addition, the measurable investigation is completed on the bases of the vitality utilization of the client in Pakistan. Discoveries: The sunlight based force can spare our vitality cost up to 208 volts since typical force supply takes a shot at 220 volts and a new planned force supply can chip away at 12 volts which are excessively under 220. This examination work gives a potential system to green IoT conditions. The proposed DC power supply unit will be extremely useful to run the IoT parts legitimately on universes. In addition, as a result of the least force utilization of IoT, it additionally decreases the carbon outflows that would be useful for the condition.

1. INTRODUCTION

The web universally associates the world as a community. There are different gadgets of the Internet of Things (IoT) that help to interface things to one another, for example, sensors, RFID, autos, PC, cell phones and home apparatuses. In this way, IoT is everything around us that ought to be imparted "whenever, anyplace, any media and anything". Adjacent to different points of interest of IoT in wide rang applications, for example, social insurance, transport, industry, home, and training frameworks as appeared in Figure 1 yet it likewise devours high force and huge vitality. The IoT used various gadgets for their usefulness however it likewise requests large vitality for its different capacities. Be that as it may, this vitality request and e-squander produce worry in our condition. To beat the issues of this IoT in the savvy world advancement, as of late the green IoT is acquainted with limit the carbon discharge and force consumption¹. Because of an expanding request of IoT, the measure of power devoured by IoT gadgets is additionally goes up. Green figuring or greening IoT electronic gadgets accompanies vitality star name, which implies the gadgets are affirmed from Environmental Protection Agency (EPA) to expend low force based on appraisals. These days, organizations are centering for force and vitality sparing strategies and frameworks. They additionally have faith in utilizing green gadgets for better conditions and give inclination at its higher level². On account of eco-accommodating properties, the vast majority of the IoT sellers are putting resources into the improvement of vitality proficient gadgets which lead them to beat the

market by means of increment popular so as an expense. It, at last, decreases the use of material which is risky and furthermore reassuring the reusability of computerized gadgets. Along these lines, late research is demonstrating the most recent patterns and models for using the green figuring and furthermore advancing the merchants investments³. These green processing philosophies give security and improve the expectation for everyday comforts for the present-day world. Green figuring is the investigation and practice of structuring, assembling, utilizing and discarding PCs, servers and related subsystems, for example, screens, printers, stockpiling gadgets, and systems administration and correspondence frameworks proficiently and successfully with insignificant or no effect on the earth. It was essentially tended to by improved innovative work endeavours to lessen power use, heat transmission, cooling needs of equipment gadgets, specifically processor chips utilizing broad equipment controls⁴. These days, organizations and basic clients are managing a lot of monetary weight with respect to power charges and focusing on recouping from this issue. Along these lines, they began to turn on green registering advances and make their home and work environment eco-accommodating. As of now, the world is giving considerably more consideration and gives a high need to spare vitality without trading off effectiveness and shield the earth from e-toxics. Different associations paying little heed to their sizes are changing over the frameworks on IoT models and actualize green processing conditions for settling the ongoing power's issues and using lower vitality with best exhibitions. At last, the use of vitality and its related cost has significant influence on green registering development at national and worldwide levels. Because of higher utilization of vitality in server farms and use of PCs in ventures, green registering place a quick effect on business esteem and stay centred for its implementation⁵. New patterns of green processing center around IoT and research most recent registering models and applications with lower cost and force utilization and advance the maintainable improvement and economy and society⁶. The fundamental reason for green figuring is exceptionally related to the utilization of vitality in computational gadgets and supporting hardware alongside optional vitality customers, for example, atmosphere control during the organization.

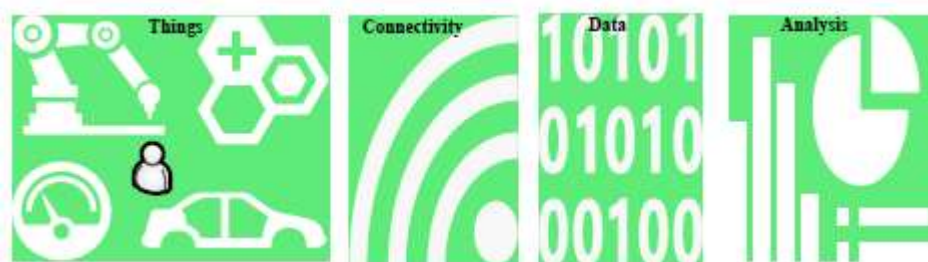

Fig.1 IoT Concept

However, before considering the problem of sustainable or green computing it is very important to take an account of other environmental concerns such as impact of material and energy on electronic device manufacturing. Similarly, after complete utilization and completion of services the recycling and disposal of these devices also leave big impact on

environment. Thus, it is necessary to consider throughout the impact of life-cycle of devices (i.e. manufacturing to disposal) on entire environment via deployments of IoT⁷. It can be seen from the above discussion that continuous advancement in technology is the key to improve the performance on given power consumption level. For example, CPUs, data storage and servers can perform and achieved higher efficiency level as compare to the pervious one on minimum energy consumptions levels⁸. Normally, desktop computers have internal power supplies which convert the AC power supply i.e. 120V to DC voltages for the other subcomponent of the computers such as microprocessor and associated components. These DC voltages converted to the appropriate levels required for subcomponents. Other principle components such as monitor; printer or plotter works on directly on AC power lines which are provided either directly from the main line or from a feed-through path which is allocated in the back of computer as a plug. At the time of running programs and data on the personal computer may loss during computing environment of AC power loss. Moreover, due to the fluctuation of AC power lines resultant in damage of various main components like disk drives etc. Even slight glitch in AC power can cause of a data loss which can lead to incorrect results. Prior work provides the solutions for this AC power supply loss and one of them is uninterruptible power supplies that provide alternative power to computers. However, these solutions are not enough in terms of efficiency neither integrated in the circuits. Furthermore, an invention came up with idea that an integrated uninterruptible power supply which provide both AC and DC for personal computer. An another approach has been proposed in which emergency power supply unit is designed which firstly detect the AC power failure and then in second phase SC transformer with a high step-up transformer is utilized to supplies power of commercial level high voltages¹⁰. From the literature it is clear that the power and energy supposed to be a key part of the solutions when considering the design aspects across a range of super computer to data center computing. Study shows that industries and organizations are given importance to energy efficient methods for desire work.

Meanwhile pervious work can be summarized into simple works i.e. "Avoid waste". The recent research is conducting to finding on the source and reasons of wastage and figuring out to minimize this form environment. The energy awareness system strategies are totally based on green computing in IoT. This strategy does not affect directly the current applications but it also controls the power consumptions aspects regarding underlying hardware utilization. Basically, IoT makes the working place and home smarter (automatic) system to turn off, on and other control management¹¹. The major reason behind the growth of internet is the popularity of IoT in our societies. Meanwhile, IoT and other industrial computers also leave some impact on environment. According to the statistics, total amount of global data center power consumptions is about 2% of total carbon-di-oxide emission. IoT and other computer based systems and equipment produced 35 million tons of exhaust which is equivalent to carbon emission in any industry. Green IoT growing since few years back because of constant pressure on IoT energy usage. Green IoT consists on green products and eco-friendly equipment to reduce carbon emission and enhance the energy efficiency.

2. PROPOSED DESIGN

In a large portion of the underdeveloped nation, there is the issue of lack of power and changes in the voltages which harms the greater part of the gadgets. Right now the thought is proposed to chip away at 12 volts rather on 220 volts. So as to accomplish this thought, a circuit is structured of a 12 volts DC Power Supply Unit (PSU) for some IoT gadgets which will take a shot at batteries/nearby planetary group without bringing down the presentation of the framework. Figure 2 portrays the transformation of 12V force supply into 5V for the simplicity of electronic circuit sub-segments. Ordinarily, give or take five percent run from the ostensible proposed setting is satisfactory.

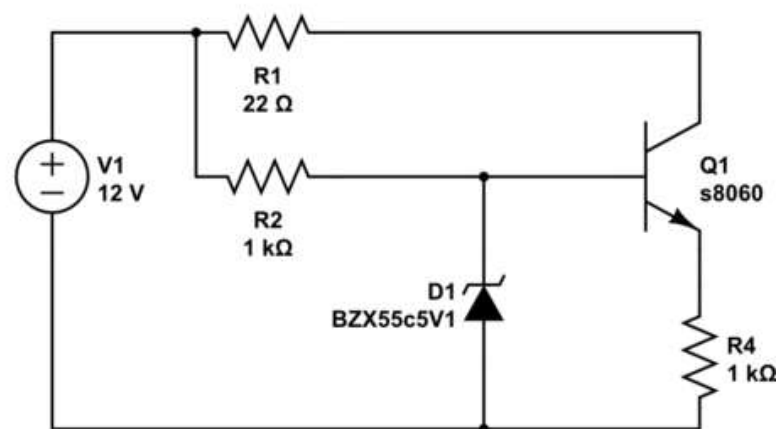

Fig 2 12v dc to 5v dc converter circuit diagram

3. DISCUSSION AND COMPARATIVE ANALYSIS ON ENERGY CONSUMPTION

From the literature it is clear that computer and laptop consumptions leave impact on environment via releases toxic chemicals and carbon dioxide with the usage of huge electricity. An estimated statistics regarding the energy consumptions and CO₂ emission in Pakistan for desktop and laptop. Through the statistics of Pakistan, it is calculated that up to 27% of total 170 million populations consumed the overall energy in different industries and home computers. Approximately, among this 27% user, 20% are desktop and 7% are laptop users. The energy consumption on daily and yearly basis data is calculated and determined in Whr. huge energy consumption is shown via calculated data i.e. 47.6 GW/hr daily and 17374 GWhr on yearly basis with a toxic release of 12161 million ton of CO₂ yearly. This hazard spills environment about and identifying an alarming situation for Pakistan. Several survey projects have been done on this issue and suggested a green computing system for real time PV applications. From the data it can see that although energy consumption for laptop is less than desktop, but still yearly massive electricity consumption takes place. Thus there is a need of a solution or system that reduces carbon emission in computer based industries. In order to overcome this environmental threat, a novel energy efficient DC power supply is proposed in

this study. The same statistics as discussed in Table 1 applied on newly designed circuit and calculates some experimental data on power consumption and carbon emission. By utilizing 12 volts DC Power Supply Unit (PSU) an experiment is conducted on desktop computer as considering an example. The digital electronic components and circuits in the desktop computer system such as motherboard, adapter cards, and disk drive logic boards typically uses the +3.3 V or +5 V power and the motors like disk drive motors and any fan uses the +12 V power. To provide such amount of voltages to particular component, there are voltage regulators on the motherboard or in other components which convert these standard voltages to others as necessary requirements or according to the component consumption. In Figure 2, the circuit shows the voltage conversion from 12 volts to 5 volts and Figure 4 shows the voltage conversion from 12 volts to 3.3 volts which could be the required amount of voltage needs to run a sub component.

Table 1. Energy consumption of desktop

Sl. No.	Parameter	Traditional	Proposed design
1.	Users Approx.	34 Millions	34 Millions
2.	Average energy consumption	175 W/hr in 1 hour	85 W/hr in 1 hour
3.	Daily energy consumption	175W/hr*8 hr =1400 W/hr	85W/hr*8 hr =680 W/hr
4.	Users daily consumption	34M*1400W/hr =47.6GW/hr	34M*680W/hr =23.120GW/hr
5.	Yearly consumption	47.6GW/hr*365 =17374GW/hr	23.12GW/hr*365 =8438GW/hr

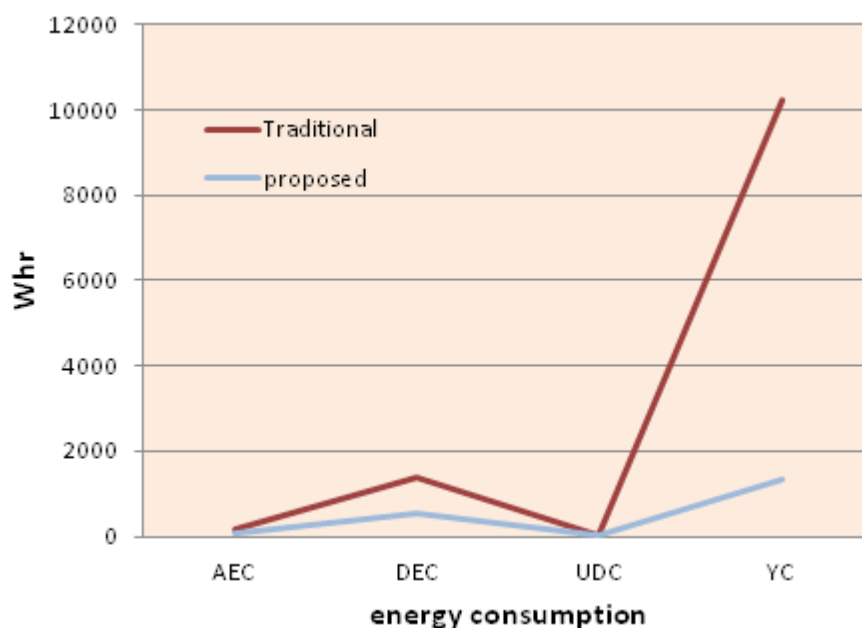

Figure 3. Comparative analysis of energy consumption.

The status of energy consumption and carbon emissions by desktop computer users by utilization of proposed solar based DC power supply unit is calculated in Table 2. The marginal reduction i.e. 720Whr in energy consumption of daily basis and 8936GWhr on yearly basis of desktop computer is shown from the Figure 3. Similarly, the carbon emission is reduced up to 50%. Thus estimated results from the proposed novel DC power supply circuit shows a

marginal result and could be very useful for industries without compromising on efficiency and can contribute in green computing.

Table 2. Co2 Emission in 1 year in Pakistan

Parameter	Traditional	Proposed Design
CO ₂ annual emission	$0.7 \times 17374 = 12161$ Million ton	$0.7 \times 8438 = 5906.6$

4. CONCLUSIONS

The tremendous development in IoT brings many advantages. However, this growth of IoT demands for high energy consumption with hazardous emission and e-waste. In this study, the idea of solar based DC power supply is introduced in order to solve the problem of shortage of electricity and fluctuations in the voltages in under developing country and a huge threat of Co2e for environment. These problems may increase the damages most of the electronics devices of IoT as well as contribute to global energy. Firstly, the main purpose of introducing solar DC power supply unit is that IoT devices can not directly connected to solar system because they need an internal power supply unit that should work on 12V and can supply the desired voltages to subunit of the system. Secondly, this new DC power supply unit will be very helpful to run the IoT components directly on solar systems. Moreover, because of minimum power consumption of IoT it also reduces the carbon emissions